

Spherical roller bearings, cylindrical and tapered bore

Principal dimensions			Basic load ratings		Speed ratings	Limiting speed	Designation
d	D	B	dynamic C	static C0	Reference speed		* SKF Explorer bearing
mm			kN		r/min		-
130	200	52	452	610	2800	3600	23026 CCK/W33 *

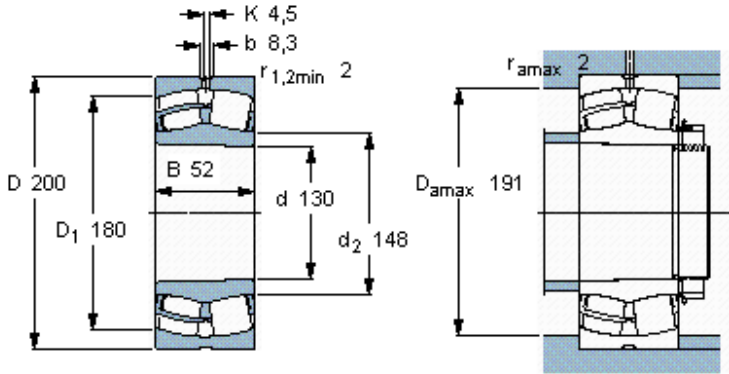

Tapered bore, taper
1: 12

- Calculation factors**
- e 0,23
 - Y_1 2,9
 - Y_2 4,4
 - Y_0 2,8